

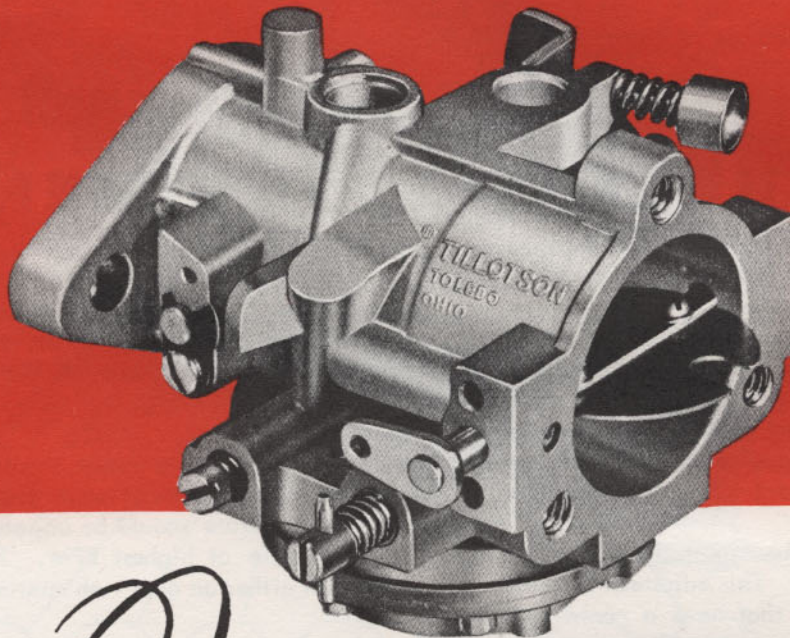

HR SERIES *Carburetor*



Introduction

The HR series diaphragm carburetor has been developed by the Tillotson Manufacturing Company for engines with a displacement of from 12 to 25 cubic inches per cylinder. It is available as a complete fuel system including carburetor, integral fuel pump and filter for two stroke cycle engines or as a carburetor and integral fuel filter for four stroke cycle engines.

The diaphragm controlled metering system allows precise fuel metering to the engine at extreme tilt angles and prevents fuel level changes due to vibration. The dual venturi used in this model series multiplies the venturi pressure drop causing fine atomization of the fuel that is delivered from the main fuel nozzle so that the fuel reaches the engine as a combustible fog instead of a fluid stream. The main benefit of this venturi system is increased power and fuel economy.

Designed with a minimum number of parts, this compact unit has retained the dependability and easy servicing features of the smaller Tillotson diaphragm carburetors that have been in use throughout the world for several years.

Information contained in the following pages is presented as an aid to understanding the construction, operation and servicing of the HR series carburetor.

If further data is required, please contact

TILLOTSON MANUFACTURING CO. Parts & Service Division
761-69 Berdan Avenue • Toledo, Ohio 43612

HR SERIES

SERVICE MANUAL

CARBURETOR ADJUSTMENT

The high speed and idle mixture screws have normal right hand screw threads. These adjustments are turned clockwise to close, or lean the mixture, and counter-clockwise to open, or enrichen the mixture. The starting adjustment opening for a new unit, or a carburetor that has not been run on the engine, is one full turn open on both the high speed and idle mixture screws.

The idle speed screw should be adjusted to open the throttle shutter a small amount. This adjustment should be carefully made on vehicles that have a centrifugal clutch drive arrangement; a very high idle speed may cause the clutch to engage and the vehicle may start to move.

Open the fuel line shut off valve, if your engine is equipped with one, and close the choke shutter. Open the throttle about one quarter of full travel and firmly pull the starting cord until the engine fires. Open the choke shutter far enough to allow the engine to idle until it has warmed up enough to run continuously with the choke fully open. Do not race a cold engine.

Adjust the idle mixture screw to obtain a smooth, steady idle, and re-adjust the idle speed screw to obtain the idle speed recommended by the engine manufacturer. Re-check the idle mixture adjustment at the

recommended idle speed. An over rich idle mixture will cause the engine to fire unevenly and there will be smoke from the exhaust. A lean idle mixture will usually cause backfiring.

The high speed mixture screw should be adjusted with the engine at fully open throttle and under normal full load. The mixture should be adjusted to allow the engine to operate at highest RPM. The speed will decrease with either an over rich mixture or lean mixture.

The above procedure need not be repeated each time the engine is started. The adjustments will remain in position and will not require frequent re-adjustment.

After the carburetor has been correctly adjusted, the engine should start easily. To start a cold engine, close the choke shutter, open the throttle about one quarter of full travel, firmly pull the starting cord until the engine starts, open the choke far enough to allow the engine to idle until it has warmed up and can run continuously with the choke fully open.

To start a warm engine, pull the starting cord. It should not be necessary to use the choke unless the engine is overheated and fuel vapor is present in the fuel lines.

... DO NOT FORCE MIXTURE SCREWS INTO THEIR SEATS!

(If the engine fails to start, see the Trouble Data Section.)

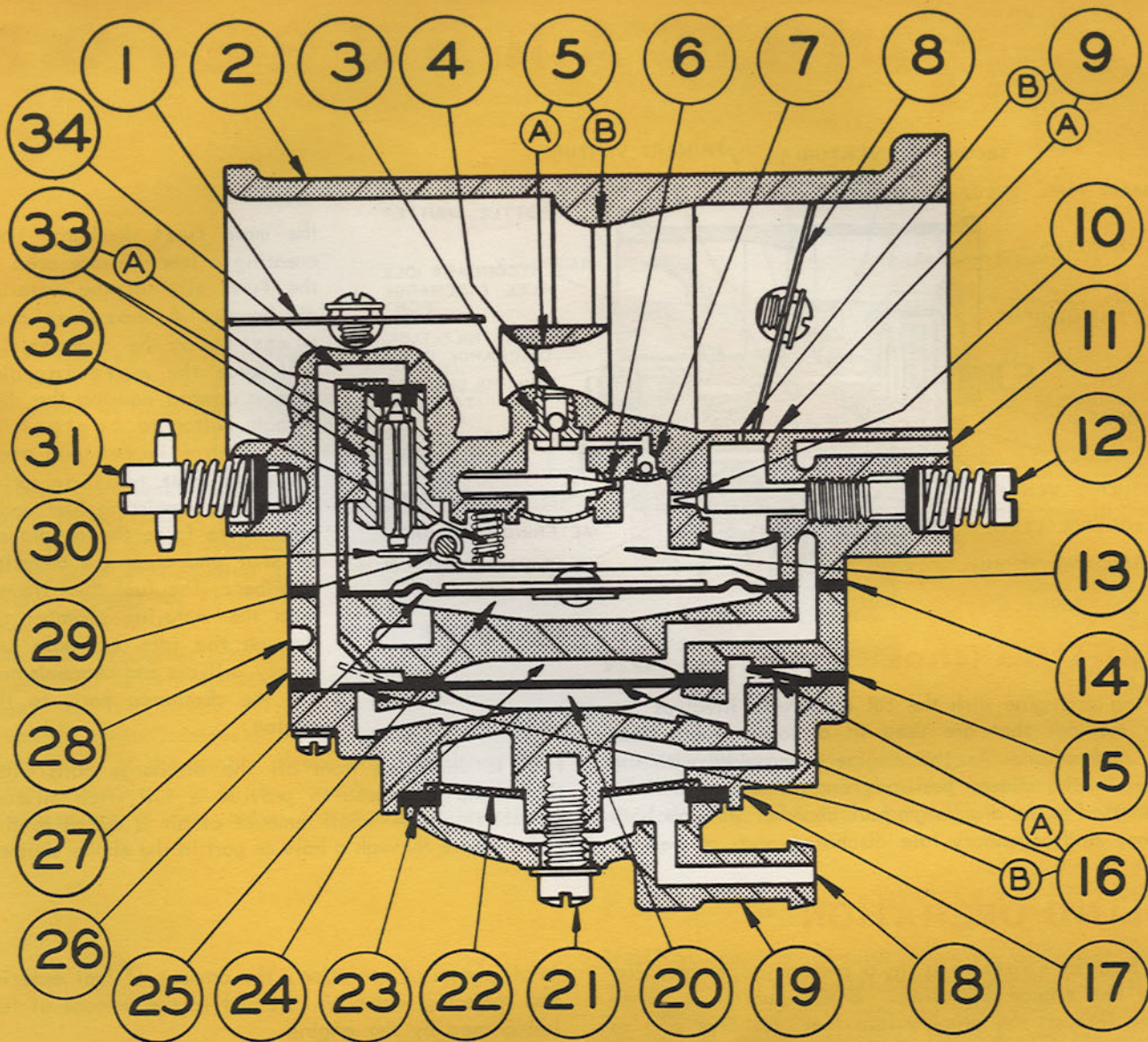

HR SERIES CARBURETOR NOMENCLATURE

- | | |
|-----------------------------------|------------------------------------|
| 1. CHOKE SHUTTER | 17. FUEL PUMP COVER |
| 2. BODY | 18. FUEL INLET |
| 3. MAIN FUEL CHECK VALVE | 19. STRAINER COVER |
| 4. MAIN FUEL DISCHARGE PORT | 20. FUEL PUMP CHAMBER |
| 5A. PRIMARY VENTURI | 21. STRAINER COVER RETAINING SCREW |
| 5B. SECONDARY VENTURI | 22. FUEL STRAINER SCREEN |
| 6. HIGH SPEED MIXTURE ORIFICE | 23. STRAINER COVER GASKET |
| 7. POWER VALVE | 24. PULSE CHAMBER |
| 8. THROTTLE SHUTTER | 25. ATMOSPHERIC CHAMBER |
| 9A. PRIMARY IDLE DISCHARGE PORT | 26. METERING DIAPHRAGM |
| 9B. SECONDARY IDLE DISCHARGE PORT | 27. DIAPHRAGM COVER |
| 10. IDLE MIXTURE ORIFICE | 28. ATMOSPHERIC VENT |
| 11. IMPULSE PORT | 29. FULCRUM PIN |
| 12. IDLE MIXTURE SCREW | 30. INLET CONTROL LEVER |
| 13. METERING CHAMBER | 31. HIGH SPEED MIXTURE SCREW |
| 14. DIAPHRAGM GASKET | 32. INLET TENSION SPRING |
| 15. FUEL PUMP GASKET | 33. INLET NEEDLE & SEAT |
| 16. FUEL PUMP DIAPHRAGM | 33A. INLET SEAT GASKET |
| 16A. PUMP DIAPHRAGM INLET VALVE | 34. FUEL INLET SUPPLY CHANNEL |
| 16B. PUMP DIAPHRAGM OUTLET VALVE | |

SEE FOLLOWING PAGES FOR OPERATIONAL DATA

HR CARBURETOR

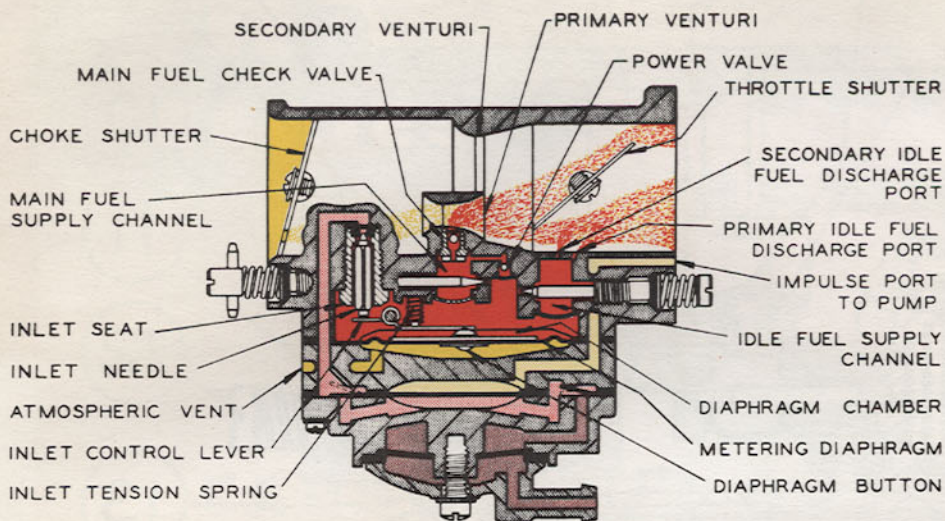

the main fuel discharge port, creating a low pressure area on the fuel side of the metering diaphragm. Atmospheric air pressure on the opposite side will force the metering diaphragm upward causing the diaphragm button to contact the inlet control lever and overcome the inlet tension spring pressure, permitting fuel under pressure to force the needle off its seat and enter the metering chamber. The fuel then travels from the metering chamber up through the idle and main fuel supply orifices and channels and out the discharge ports to the engine.

STARTING (choke) OPERATION

Starting an engine with the HR carburetor involves the same methods that are used in a conventional float type carburetor. As the engine is cranked with the choke in the closed position, engine suction will be transmitted to the diaphragm fuel chamber through both primary and secondary idle discharge ports as well as

Fuel is delivered from all the discharge ports when the choke is closed to provide a full, rich mixture for starting. A small amount of air is added to this rich mixture through a hole or port in the choke shutter.

IDLING OPERATION

The throttle shutter is in a partially open position when the engine is idling. Engine suction is transmitted through the primary idle fuel discharge port to the fuel chamber side of metering diaphragm via the idle fuel supply channel. Again, the metering diaphragm is forced upward by atmospheric pressure, depressing the inlet control lever and permitting fuel under pressure to force the inlet needle off its seat and enter the metering chamber. The fuel is then drawn up through idle fuel adjustment orifice and delivered to the engine through primary idle discharge port.

In all phases of operation, the amount of fuel entering the metering chamber is equal to the amount of fuel being used by the engine.

The entire carburetor bore from the air inlet to the back of the throttle shutter is at atmospheric pressure during idle operation. The ball check valve in the main fuel port is closed to prevent air from entering the metering chamber.

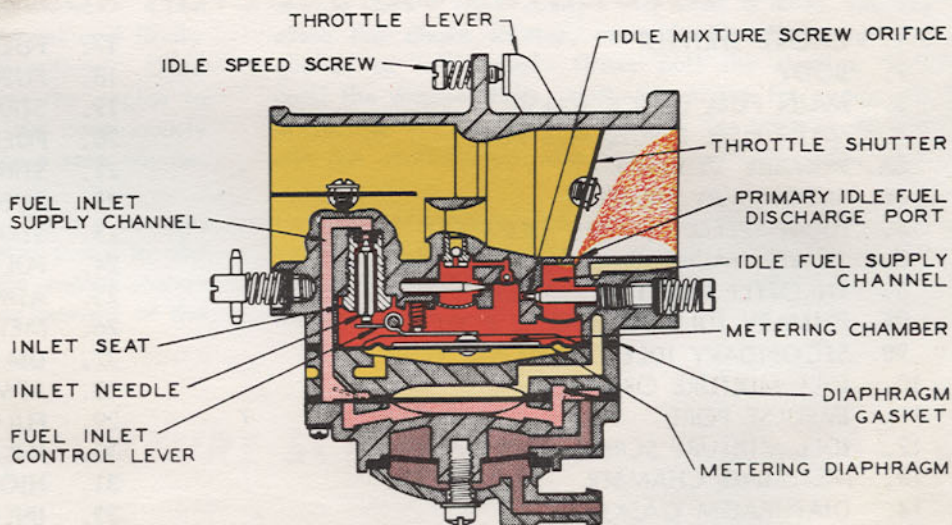

OPERATIONAL DATA

INTERMEDIATE OPERATION

Fuel is delivered into and through the carburetor in the same manner as when the engine is idling. However, as the throttle opens and engine speed increases, more fuel is demanded from the carburetor and supplied to the engine by the secondary idle discharge port located immediately behind the throttle shutter.

As the throttle shutter continues to open and engine speed increases, the velocity of air through the venturi creates a low pressure area at the venturi throat and diminishes the suction on engine side of the throttle shutter. When the pressure at the venturi throat is less than that

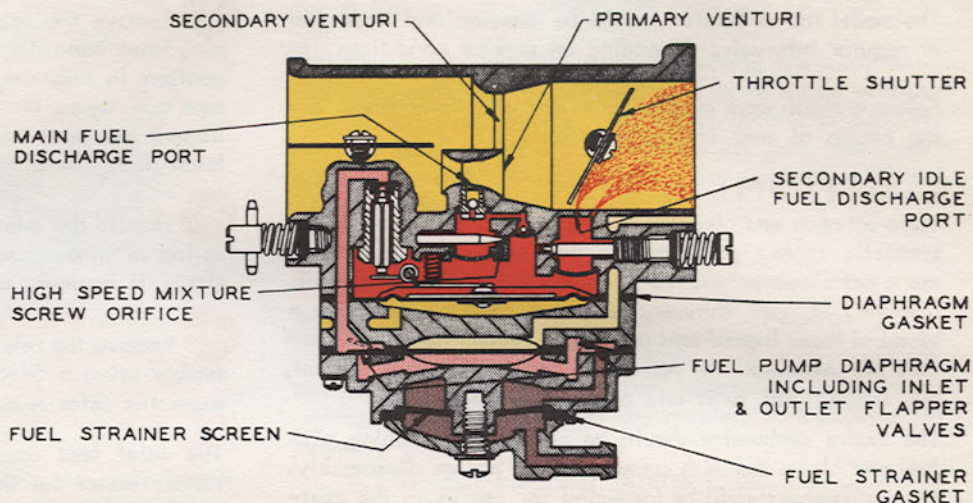

existing within metering diaphragm fuel chamber, fuel is drawn up through high speed mixture screw orifice and out main fuel discharge port.

HIGH SPEED OPERATION

As the throttle shutter progressively opens from intermediate position to full open position, the air velocity through the venturi increases and fuel is metered up through high speed mixture screw orifice and main fuel discharge port in accordance with the power requirements of the engine. The action of the metering diaphragm is the same as previously described with suction required to operate the diaphragm being transmitted through the main fuel discharge port.

FUEL PUMP OPERATION

The fuel pump is a pulse operated diaphragm type, where the inlet and outlet check valves are flap valves. The pumping pulse is supplied from the changes in engine base pressure caused by the motion of the piston.

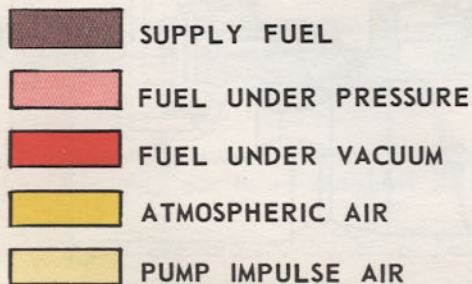
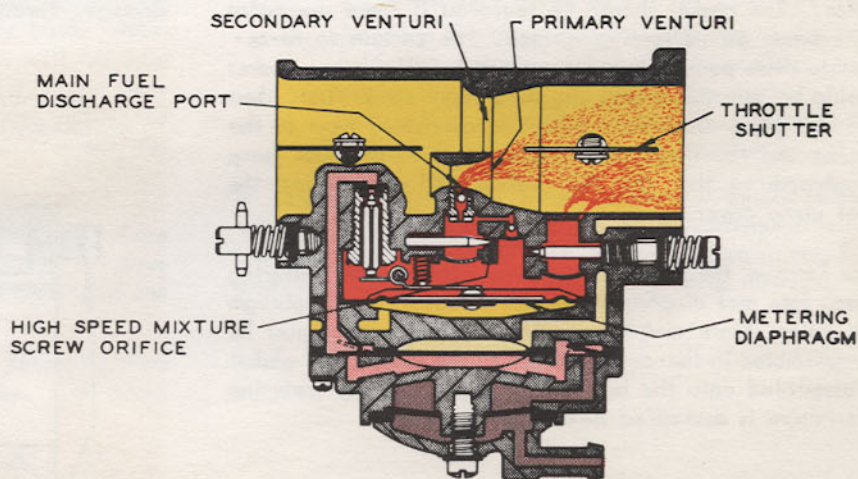

SERVICE DATA

HOW TO DISASSEMBLE FOR CLEANING AND REPAIR

The model HR carburetor should be cleaned and inspected at regular intervals, depending on service conditions.

Select a clean work area because dirt and carelessness are the causes of most carburetor trouble.

CAUTION:

Some solvents and cleaners have a damaging effect on the synthetic rubber parts used in carburetors. It is best to use a petroleum product for cleaning. Do not use alcohol, acetone, lacquer thinner, benzol or any solvent with a blend of these ingredients unless the rubber parts and gaskets are removed. If you are in doubt about your solvent, test a used part in it and observe the reaction.

The entire carburetor should be cleaned by flushing with fuel and blown dry with compressed air before disassembly. The carburetor should be inspected for cracks in the casting, bent or broken shafts, loose levers or swivels and stripped threads.

1 Inspect the idle speed screw, washer and tension spring. Inspect the casting for thread damage. In the event the casting is stripped of threads, repair by inserting an 8-32 Heli-coil 3/16" long.

2 The fuel inlet and filter cover are removed by removing the center screw. Remove the filter cover, the cover gasket and the filter screen. The filter screen should be cleaned by flushing with fuel or solvent and blowing with compressed air. It is advisable to replace the gasket whenever the filter screen is serviced. Flush all dirt from the plastic cover before assembly.

3 Remove the six body screws and the fuel pump cover casting. Remove the fuel pump diaphragm and gasket. Inspect pump diaphragm; it must be flat and free from holes. The gasket should be replaced if there are holes or creases on its sealing surface. Be certain to re-assemble these parts in the correct order. The pump gasket should be assembled onto the diaphragm cover first, then the fuel pump diaphragm should be assembled next to the gasket and the flap valve member next to the fuel pump diaphragm so that the flap valves will seat against the fuel pump cover.

4 Remove the diaphragm cover casting, the metering diaphragm and diaphragm gasket. Inspect the diaphragm for holes, tears and imperfections. These parts must be re-assembled in the correct order. The diaphragm gasket is assembled onto the body casting first and the metering diaphragm is assembled next to the gasket.

5 Remove the fulcrum pin retaining screw, the fulcrum pin, inlet control lever and the inlet tension spring. Use caution in removing these parts because the spring pressure may cause the inlet lever to fly out of the casting. Inspect the parts for wear or damage. The inlet control lever must rotate freely on the fulcrum pin.

6 Handle the inlet spring carefully. Do not stretch this spring or in any way change its compression characteristics. If in doubt about its condition, replace it.

7 Remove the inlet needle. Remove the inlet seat assembly using a 5/16 inch thin wall socket wrench. Remove the inlet seat gasket.

The inlet seat assembly consists of a brass cage and a rubber insert for the inlet needle seat. The insert goes into the cage only one correct way. Looking at the insert, one side is flat and smooth; the other side has a ridge or rim molded around the outside edge. This ridge is to be assembled away from the inlet needle point.

Some models of the HR carburetor are equipped with a rubber tipped needle, a brass inlet seat and a copper gasket. The installation instructions below are applicable to both types of inlet seats.

The inlet needles and seats are matched and tested for leaks at the factory and the parts should not be interchanged - they must be kept in matched sets. When installing the insert cage into the carburetor body, use a new gasket. Do not force the cage, as you may strip the threads or distort the insert. Use a torque wrench to apply 25 to 30 inch-pounds pressure. The needle and seat assembly must be clean to insure correct performance.

8 Remove and inspect the points of both the high speed and idle mixture screws. Notice the idle mixture screw point has the step design to minimize point and casting damage. Through misuse, either mixture screw point may

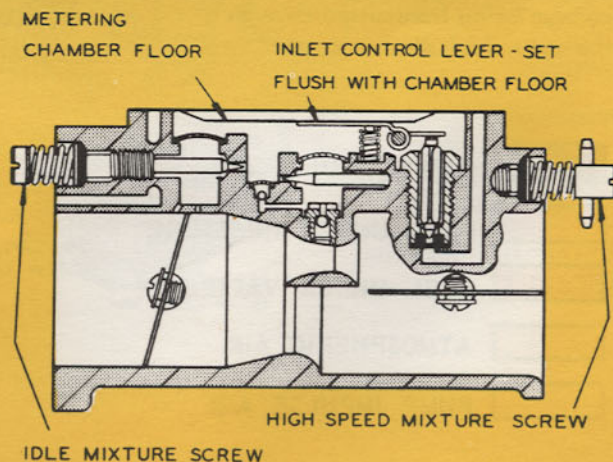

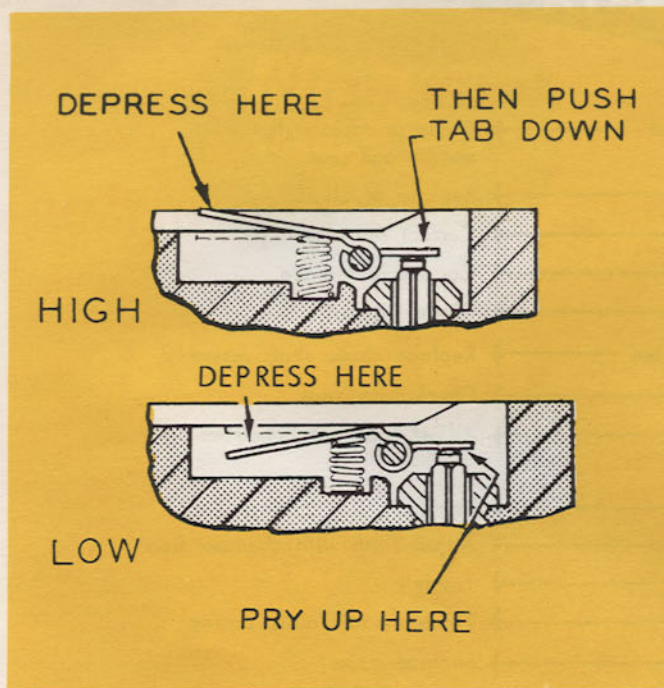

be bent, extruded from being forced into the casting seat or possibly broken off in the casting. If either mixture screw is damaged, be sure to inspect the condition of the casting. If the adjustment seats are damaged, a new body casting is required.

9 The idle bypass ports and main nozzle ball check valve are sealed from the metering chamber by welch plugs. It is seldom necessary to remove either of these plugs because there is no wear in either section, and any dirt that may accumulate can usually be blown out with compressed air through the mixture screw holes. If the carburetor is unusually dirty and the welch plugs must be removed, it will require careful work. Drill through the welch plug, using a 1/8 inch drill. Allow the drill to just break through the welch plug. If the drill travels too deep into the cavity, the casting may be ruined. Pry the welch plug out of its seat, using a small punch.

Inspect the idle bypass holes to insure they are not plugged. Do not push drills or wires into the metering holes. This may alter carburetor performance. Blow plugged holes clean with compressed air. Remove the main nozzle ball check assembly with a screwdriver of correct blade width. If this ball check is defective, the engine will not idle unless the high speed mixture screw is shut off or there will be poor high speed performance with the high speed mixture screw adjusted at 1-1/4 turns open. Replace the defective part.

10 The choke and throttle shafts may be removed if there is evidence of wear on these parts. The shafts do not have to be removed before cleaning the body casting if the parts are not worn.

Mark the throttle and choke shutters before removing them so that they can be re-assembled correctly. The edges

are tapered for exact fit into the carburetor bores. Remove two screws and pull the shutter out of the carburetor body. Remove the throttle shaft clip and pull the shaft out of the casting. Examine the shaft and the body bearings for wear. If the shaft shows excessive wear, replace it. If the body bearing areas are worn, replace the body casting. Remove the choke shaft from the body carefully so that the friction ball and spring will not fly out of the casting. Inspect the shaft and bushings.

11 Clean all parts before re-assembling the carburetor. The metal parts can be cleaned in a good grade of commercial carburetor solvent. If the carburetor is not very dirty, it can be cleaned by blowing the parts with compressed air and carefully blowing out each channel and orifice in the castings.

REPLACE ALL WORN PARTS

12 Assemble the carburetor. Make certain that all parts are kept clean before they are assembled to the body casting. Few measurements are required to complete the assembly of this simple unit:

1. Tighten the inlet seat to 25-30 inch-pounds of torque.
2. Adjust the inlet control lever so that the center of the lever that contacts the metering diaphragm is flush to the metering chamber wall as shown in the drawings.
3. Install new welch plugs at the nozzle well and bypass chamber if the original parts were damaged or removed. Place the new welch plug into the casting counter bore convex side up and flatten it to a tight fit, using a 5/16 inch flat end punch. If the installed welch plug is concave, it may be loose and cause an uncontrolled fuel leak. The correctly installed welch plug is flat.
4. Assemble the gaskets, diaphragms and castings in the correct order.
5. Assemble the throttle shaft into the carburetor body and attach the throttle shaft clip before assembling the throttle shutter. With the shaft secured in place, assemble the shutter into the shaft. Make certain that the shutter fits accurately into the throttle bore in the closed position.
6. Assemble the spring and ball into the choke shaft hole and assemble the shaft into position. Assemble the shutter into the choke shaft. Make certain that the choke shutter fits tightly to the carburetor bore in the closed position.

A carefully rebuilt HR model carburetor should perform well. The two most likely causes of carburetor failure are dirt and a careless repair job. A clean, carefully assembled unit should be nearly as good as new.

... See the following page for operational trouble and remedy data.

TROUBLE DATA

TROUBLE	POSSIBLE CAUSE	REMEDY
CARBURETOR FLOODS	Dirt or foreign particles preventing inlet needle from seating	Clean or replace the inlet needle and seat
	Stuck inlet lever	Replace or clean
	Spring not seated on lever dimple	Correct the assembly
	Diaphragm improperly installed	Correct or replace
	Plugged air filter	Clean filter
	Faulty choke stop allowing choke to close	Replace choke shaft assembly
	Fuel tank pressure build-up	Check tank vent
	Inlet lever adjusted too high	Adjust flush with chamber floor
ENGINE WILL NOT ACCELERATE	Idle mixture too lean	Readjust
	Low inlet lever setting	Adjust flush with chamber floor
	Carburetor loose on manifold	Tighten
	Diaphragm cover plate loose	Tighten cover plate screws
	Diaphragm gasket leaking	Replace gasket
	Fuel channels plugged	Clean carburetor
	No fuel	Fill fuel tank
ENGINE WILL NOT IDLE	Incorrect adjustment	Readjust
	Fuel channels plugged	Clean carburetor
	Inlet lever set incorrectly	Set flush with chamber floor
	Sticking inlet needle or lever	Replace or clean
	Pump pulse hole not aligned with flange hole	Align
	Throttle shutter cocked in throttle bore, causing fast idle	Adjust shutter position
	Faulty nozzle check cage	Replace nozzle assembly
	Welch plug does not seal	Replace welch plug
	Diaphragm vent plugged	Clean
	Tank vent not operating	Repair
ENGINE RUNS OUT LEAN	Fuel line plugged	Clean fuel line
	Leak in fuel system from tank to pump	Replace line
	Pump pulse hole plugged or not aligned with engine pulse hole	Clean or correct alignment
	Pump valve flippers damaged or bent off ports	Replace pump diaphragm
	Dirty inlet screen	Clean filters
	Clogged fuel channels	Clean carburetor
	Incorrect inlet lever adjustment	Set lever flush with chamber floor
	Low fuel supply	Fill fuel tank
CARBURETOR RUNS RICH WITH MIXTURE SCREW SHUT OFF	Welch plugs not sealing	Replace welch plugs
	Ruptured pump diaphragm	Replace pump diaphragm
	Carburetor flooding	See above

NOTE: - Turn mixture screws carefully . . . **DO NOT FORCE MIXTURE SCREWS INTO SEATS.**

IF TROUBLE PERSISTS,
CHECK ENGINE DATA

TILLOTSON MANUFACTURING CO.
PARTS AND SERVICE DIVISION
TOLEDO, OHIO 43612